

EVSE Testing

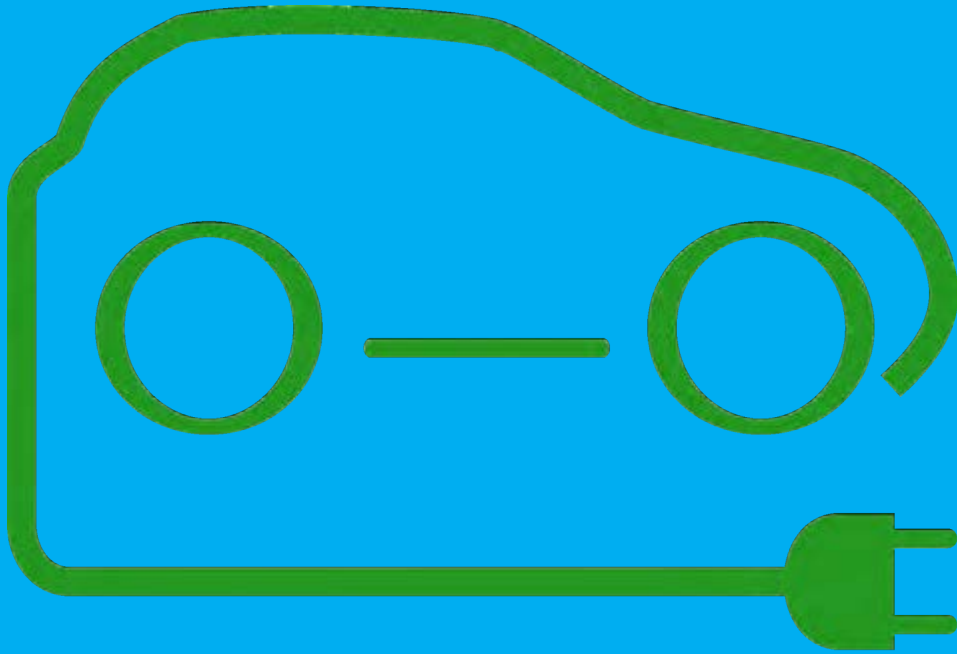

Mustafa Keskin
Product Manager

EMONA
INSTRUMENTS PTY LTD

A high-tech engineering company specialising
in electronics, electrical, education and additive
manufacturing equipment.

www.emona.com.au

 **METREL**[®]

AGENDA

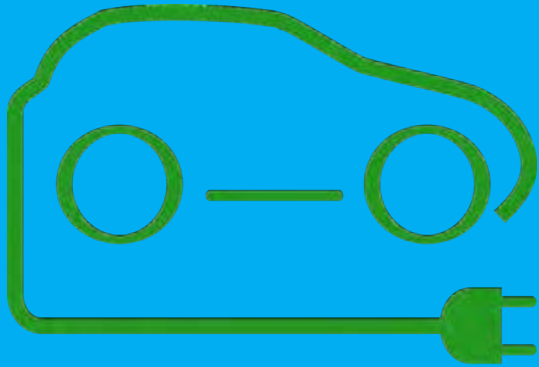

- 1) Why Test EV Charge Stations
- 2) What Tests
- 3) A1532 XA Adapter
- 4) Metrel Complete Solution with Autotsequence
- 5) EVSE Test Report
- 6) Other Metrel Products

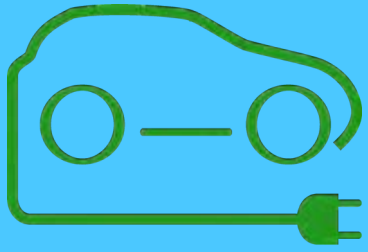

Why Test EV Charge Stations ?

AUSTRALIAN STANDARDS and Regulations(state specific)

AS NZS 3000:2018 Wiring Rules :

Section P : Guidance for Installation and location of EV
Socket Outlets and Charging Stations.

AS/NZS 3017(commissioning tests) , 3019 (periodic verification), 3760 (PAT)

RCD Protection IEC 62955 AS IEC 61851

PERIODIC VERIFICATION AS3000 APPENDIX P

Publicly available EV charging station should be inspected at least:	To verify that:
Weekly	a) Equipment is not visibly damaged
	b) EV charging Station not showing any indications of faults or errors
Yearly	Verify correct operation



- Why test ?
- The presence of possible faults cannot be seen or smelt.
- Verify correct operation of equipment (charger & cables)

What tests?

- PE conductor continuity
- Insulation resistance
- Loop impedance
- Line impedance
- RCD Tripout Time and Tripout Current

A 1532 XA EVSEAdapter

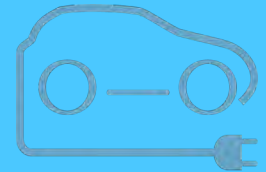

“Open” the EVSE for safe electrical testing (with MI 3155 or MI 3152)

- check the electrical parameters on the output of EVSE (Voltage, loop ,line)
- RCD testing (30 mA AC and 6 mA DC type B)
- EVSE insulation check

Connect to Tester
(3 Phase)



Scope
(CP Waveform)

RCD Auto		13:58	
Z auto 15:39			
t IΔN x1	45.	U _{in}	230 V ΔU 0.0% ✓
t IΔN x5	8.	Z (LN)	0.73 Ω I _{psc} (LN) 315 A ✓
t IΔN x0.5 >30		Z (LPE)	0.75 Ω I _{psc} (LPE) 309 A ✓
IΔ	22.	U _c	0.0 V ✓
IΔ d.c.	>13.	Z _{ref}	0.77 Ω
U _c	0.	Protection	TN red C
Use		Fuse Type	
Type		Fuse I	10 A
IΔN / IΔN d.c.		Fuse t	0.4 s
Test		Isc factor	1

Connect to Tester

A1532XA – Functional Tests

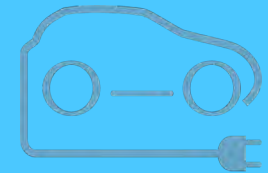

Proximity Pilot (PP)

simulation of EV cable presence and charging current.

(weakest link)

Control Pilot (CP)

simulation of electric vehicle status.

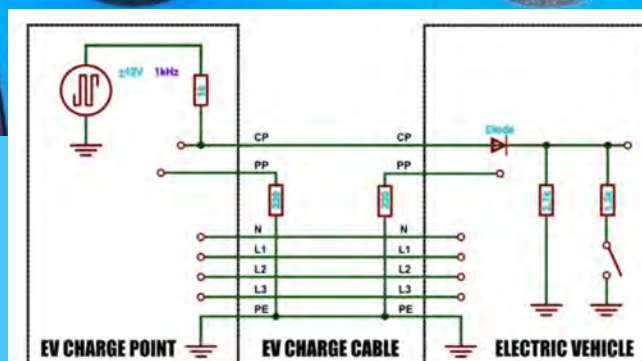

Error Simulations and Load Test - A1532XA

Error Simulation:

- a) PE open
- b) Diode short

c) CP Short



Load Test up to 13 A

- a) Single phase from socket
- b) 3 Phase from banana sockets

The METREL complete solution

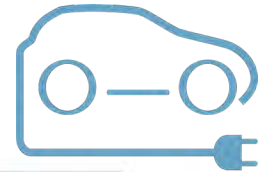

MI 3155 / + Funct. test + Auto Sequence + A 1532 → EVSE report
MI 3152

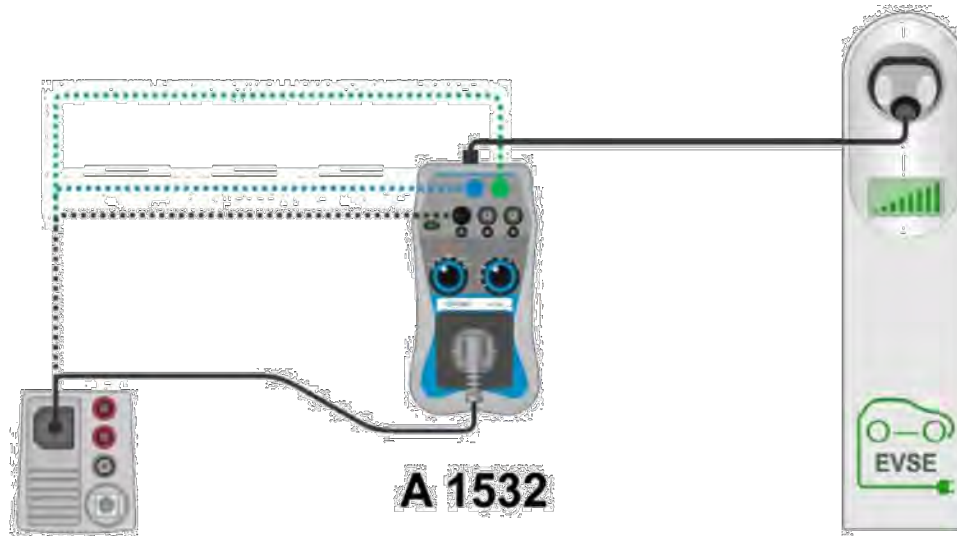

Advantage of Autosequence

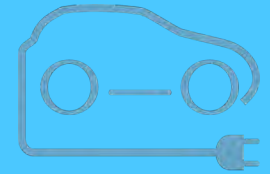

or



+ Auto Sequences®



- Series of test (functional and electrical) simplifies testing
- Instructions between steps.
- Ensure compliance with standards (pass limits set to standards).

Test procedure

Start Auto Sequence[®] & run Functional test

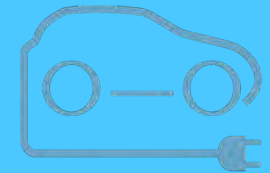

EVSE 3p No Vent trip 14:50

Check System / Fuse / RCD parameters.

Plug EV adapter into the charging station.
PP state knob set to the desired loading current.
CP state knob setting follow ABCE positions.
Fill-in status checkboxes of the inspection.

Inspection 14:51

Functional EVSE ✓

- CP states ✓
 - A-EVSE in idle state ✓
 - B-EV detected, EVSE does not charge ✓
 - C-EV is charged ✓
 - E-pilot error, charging interrupted ✓

PP

CP



Test procedure

Auto Sequence[®]: energized system (1 / 2)

1. A 1532: set CP state = C & connect test leads.
2. MI 3155: Voltage test

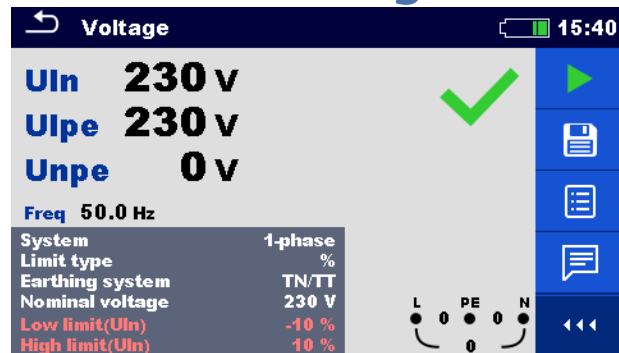

Repeat for each phase.

3. MI 3155: Z auto test

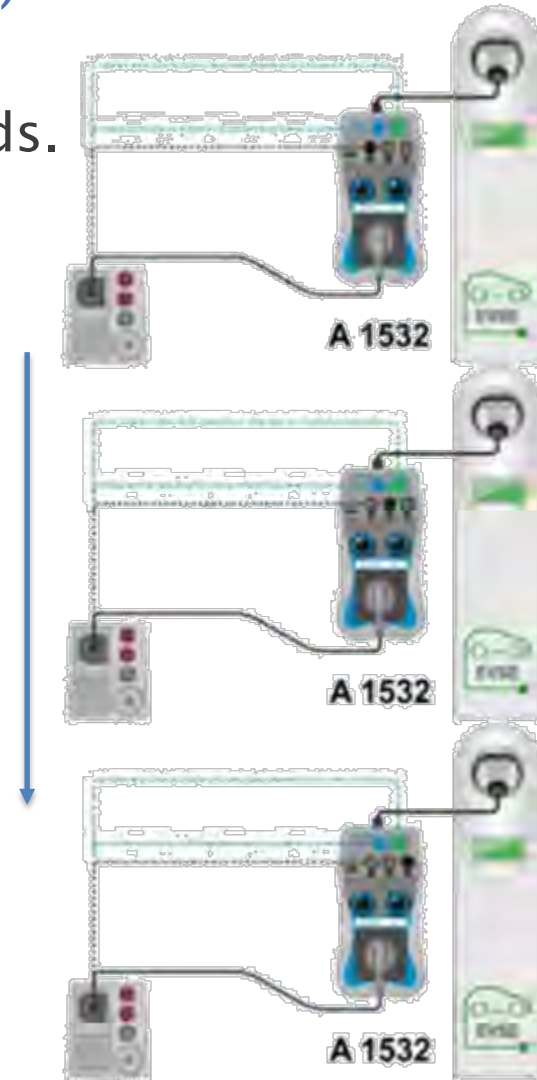
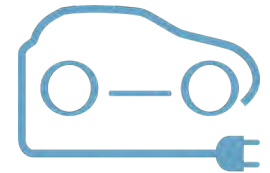
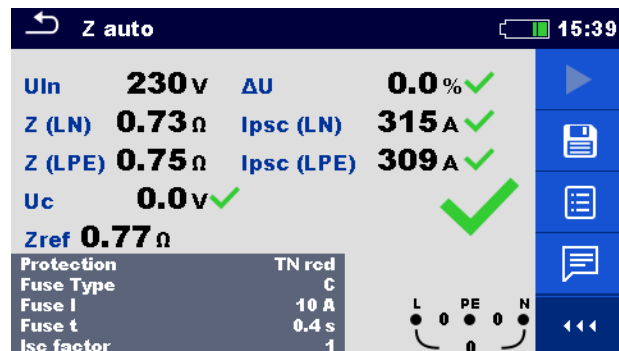

Test procedure

Auto Sequence[®]: energized system (2/2)

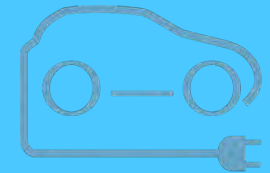

1. A 1532:

- Set CP state = C and Leave L test lead on L3 terminal.

2. MI 3155: RCD Auto test → Type A + Type B = Type EV RCD

	(+)	(-)
t IΔN d.c. x1	3.73 s	827.8 ms
t IΔN x1	26.8 ms	16.7 ms
t IΔN x2	5.6 ms	15.3 ms
t IΔN x5	4.6 ms	14.3 ms
t IΔN x0.5	≥300 ms	≥300 ms
IΔ	25.5 mA	24.0 mA
IΔ d.c.	6.0 mA	6.0 mA
Uc	0.1 V	

Use	other
Type	EV RCD
I ΔN / I ΔN d.c.	30 mA / 6 mA d.c.
Test	L/PE

Test procedure

Auto Sequence[®]: non-energized system

1. A 1532: set CP state = B & leave L test lead on L3 terminal.
2. MI 3155: R iso test → L3-PE

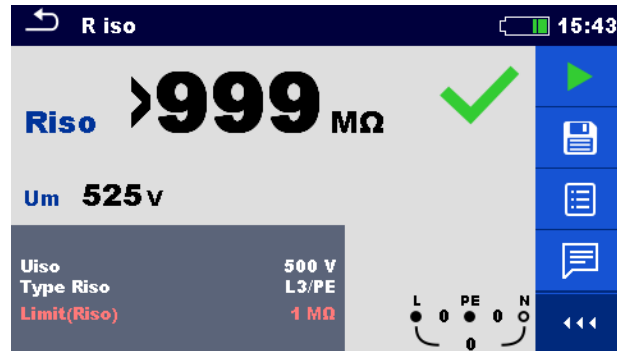

Repeat R iso test for:

- L2-PE
- L1-PE
- N-PE

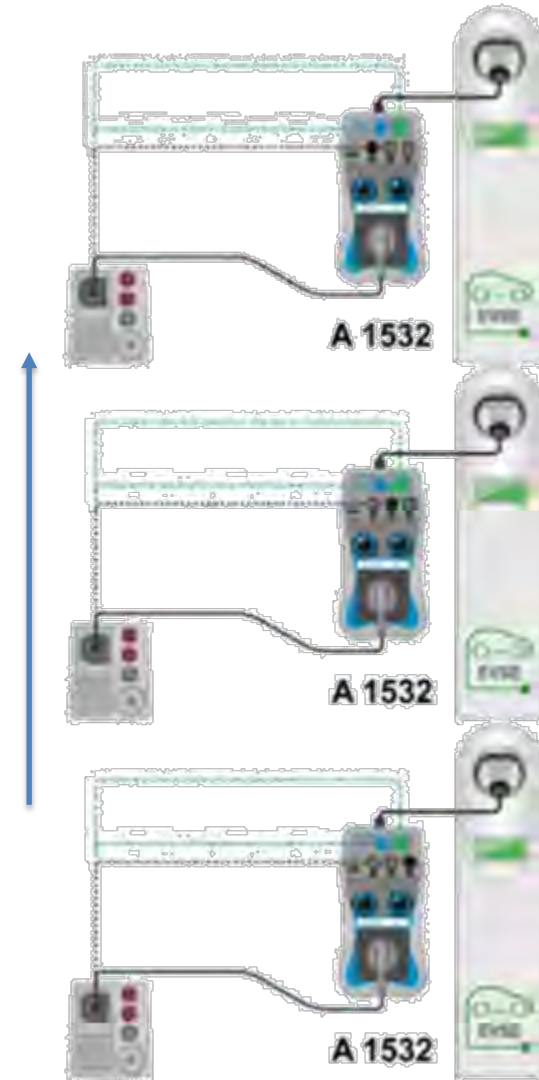
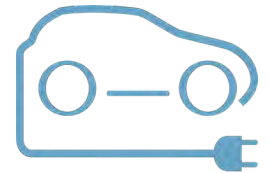

Test procedure

Create EVSE report

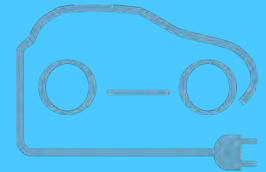

Customer No.:	Inspect. rec. No.:	Order No.:
ELECTRICAL VEHICLE SUPPLY EQUIPMENT TEST REPORT		
EVSE 3p No Vent trip - Visual Inspections		
Functional EVSE	EVSE	Pass
CP status A-EVSE in idle state B-EV detected, EVSE does not charge C-EV is charged E-pilot error, charging interrupted PP (max)		Pass Pass Pass Pass Pass
EVSE 3p No Vent trip - Single tests		
Result:	Limits:	Parameters:
Voltage EVSE		Pass
Uln: 225 V Uple: 225 V Unpe: 0 V Freq: 50.0 Hz	Uln: -10 % Uln: 10 % Uple: 207 V Uple: 253 V Unpe: 0 V Uln: 10 V	DateTime: 17/11/2017 14:28:58 System: 1-phase Limit type: % Earthing system: TN/TT Nominal voltage: 230 V
Z auto EVSE		Pass
Uln: 223 V ΔU: 0.0 % Z (LPE): 0.76 Ω Z (LN): 0.73 Ω Ipsc (LN): 316 A Ipsc (LPE): 304 A Uc: 0.0 V Zref: 0.77 Ω	ΔU: 3.5 % Ipsc (LN): 100 A Ipsc (LPE): 100 A Uc: 25 V	DateTime: 17/11/2017 14:29:08 Protection: TN rcd Fuse Type: C Fuse I: 10 A Fuse t: 0.4 s Iac factor: 1 RCD type: A IΔN: 30 mA Selectivity: G Phase: L1 I test: Low
Voltage EVSE		Pass
Uln: 223 V Uple: 224 V Unpe: 0 V Freq: 50.0 Hz	Uln: -10 % Uln: 10 % Uple: 207 V Uple: 253 V Unpe: 0 V Uln: 10 V	DateTime: 17/11/2017 14:29:16 System: 1-phase Limit type: % Earthing system: TN/TT Nominal voltage: 230 V
Z auto EVSE		Pass
Uln: 224 V ΔU: 0.0 % Z (LPE): 0.74 Ω Z (LN): 0.73 Ω Ipsc (LN): 315 A Ipsc (LPE): 309 A Uc: 0.0 V Zref: 0.77 Ω	ΔU: 3.5 % Ipsc (LN): 100 A Ipsc (LPE): 100 A Uc: 25 V	DateTime: 17/11/2017 14:29:24 Protection: TN rcd Fuse Type: C Fuse I: 10 A Fuse t: 0.4 s Iac factor: 1 RCD type: A IΔN: 30 mA Selectivity: G Phase: L2 I test: Low
Voltage EVSE		Pass
Signature:	Customer:	Operator:
		Page: 2 / 4

Customer No.: Inspect. rec. No.: Order No.:

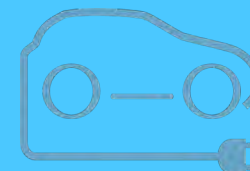

ELECTRICAL VEHICLE SUPPLY EQUIPMENT TEST REPORT

Uln: 223 V Ulpe: 223 V Unpe: 0 V Freq: 50.0 Hz	Uln: -10 % Uln: 10 % Ulpe: 207 V Ulpe: 253 V Unpe: 0 V Unpe: 10 V	DateTime: 17/11/2017 14:29:34 System: 1-phase Limit type: % Earthing system: TN/TT Nominal voltage: 230 V
Z auto EVSE		Pass
Uln: 222 V ΔU : 0.0 % Z (LPE): 0.73 Ω Z (LN): 0.71 Ω Ipsc (LN): 324 A Ipsc (LPE): 314 A Uc: 0.0 V Zref: 0.77 Ω	ΔU : 3.5 % Ipsc (LN): 100 A Ipsc (LPE): 100 A Uc: 25 V	DateTime: 17/11/2017 14:29:43 Protection: TN rcd Fuse Type: C Fuse I: 10 A Fuse t: 0.4 s Isc factor: 1 RCD type: A I Δ N: 30 mA Selectivity: G Phase: L3 I test: Low
RCD Auto EVSE		Pass
t I Δ N x1, (+): 9.6 ms t I Δ N x1, (-): 9.1 ms t I Δ N x5, (+): 8.2 ms t I Δ N x5, (-): 7.9 ms t I Δ N x0.5, (+): >300 ms t I Δ N x0.5, (-): >300 ms I Δ , (+): 28.5 mA I Δ , (-): 27.0 mA Uc: 0.3 V	Uc: 25 V	DateTime: 17/11/2017 14:32:49 Use: fixed Selectivity: G RCD type: A I Δ N: 30 mA Test: L3/PE RCD Standard: EN 61008 / EN 61009 Earthing system: TN/TT
R iso EVSE		Pass
Riso: >999 M Ω Um: 525 V	Riso: 1 M Ω	DateTime: 17/11/2017 14:34:05 Uiso: 500 V Type Riso: L3/PE
R iso EVSE		Pass
Riso: >999 M Ω Um: 525 V	Riso: 1 M Ω	DateTime: 17/11/2017 14:34:11 Uiso: 500 V Type Riso: L2/PE
R iso EVSE		Pass

Other Metrel Products

InstaltestCombo
MI3125BT



Low Cost Tester
with 6mA DC RCD test

Tester	EV RCD	Functional Test Log	EVSE Auto Sequence	EVSE Report
MI 3155				
Instaltest XD	✓	✓	✓ User defined	✓
MI 3152				
Instaltest XC	✓	✓	✓	✓
MI 3125 BT				
Instaltest Combo	✓			limited

A 1632 eMobilityAnalyser

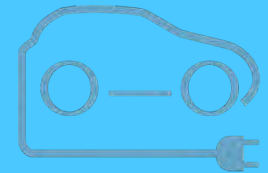

Basic features like the A 1532, plus:

- Mode 2 charging testing
- Mode 3 cable testing
- Different output errors (PE open, Diode short)
- Input errors
- EVSE monitor with A 1632
- Diagnostic test EVSE
- Bluetooth connection
- Remote operation with Android app eMobility



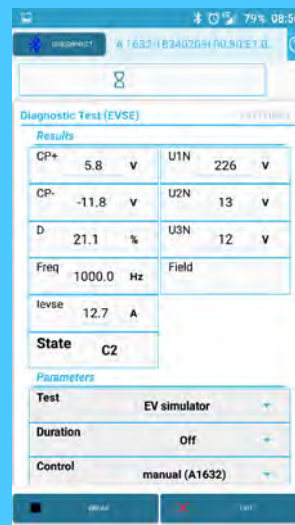





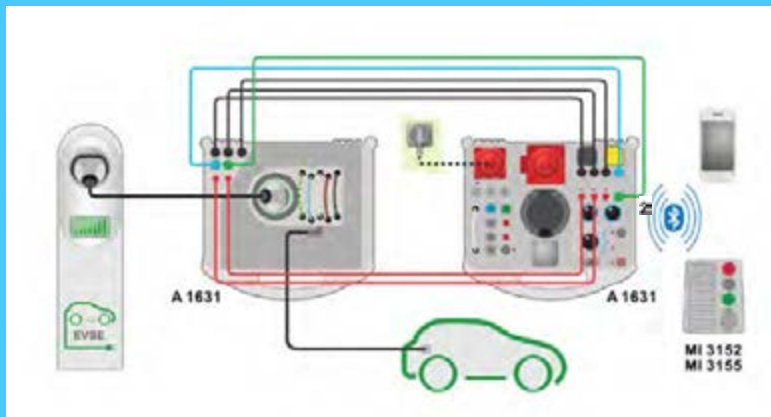

A 1532



A 1631 EV monitoring cable

- Monitoring during a.c. EV charging with up to 32 A EVSE:
 - CP signal communication monitoring during charging;*
 - PP resistance;
 - Current;
 - Voltage;
- Current and voltage verification with MI 2883 Energy Master or MI 2884 Energy Master XA;
- Possible to simulate external load (up to 13 A) via banana plugs and verify EVSE counters.

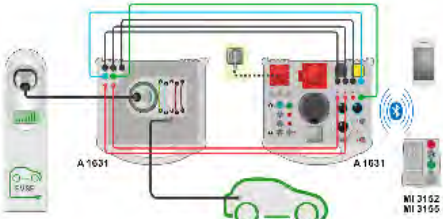
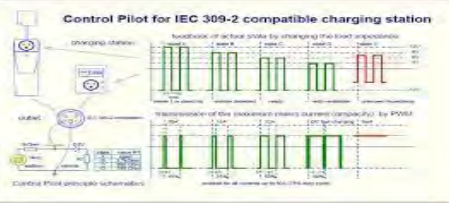

Instrument	Examples	A1532XA 	A 1632 																																
Mode 3 EVSE testing		✓	✓																																
PP state and CP state	 	✓	✓																																
Load Test		✓	With 1631																																
Mode 3 Cable Testing			✓ Insulation +Continuity																																
Mode 2 Portable Charger Testing		Limited test O/P with Autosequence and CP errors	Full Diagnostic Test and input errors																																
Input errors			L open,N open and PE open,L-PE crossed,PEExtV																																
Output errors		✓	✓ With error times																																
Monitor during EV charging upto 32A EVSE with optional A1631			CP Signal Communication PP Resistance, Current, Voltage Connect Energy Analyser MI 2883/2884 verify Current and Voltage Meters on EVSE																																
Diagnostic Test EVSE			<table border="1"> <thead> <tr> <th colspan="2">Diagnostic Test (EVSE)</th> <th colspan="2">Diagnostic Test (EVSE)</th> </tr> </thead> <tbody> <tr> <td>CP+</td><td>5.9 V</td> <td>U1N</td><td>229 V</td> </tr> <tr> <td>CP-</td><td>-11.6 V</td> <td>U2N</td><td>13 V</td> </tr> <tr> <td>D</td><td>21.3 %</td> <td>U3N</td><td>12 V</td> </tr> <tr> <td>Freq</td><td>1000.0 Hz</td> <td>req</td><td>1000.0 Hz</td> </tr> <tr> <td>evlse</td><td>12.8 A</td> <td>evlse</td><td>12.8 A</td> </tr> <tr> <td>State</td><td>C2</td> <td>toff</td><td>36 ms ✓</td> </tr> <tr> <td></td><td></td> <td>State</td><td>E</td> </tr> </tbody> </table> <p>CP to Earth Short</p>	Diagnostic Test (EVSE)		Diagnostic Test (EVSE)		CP+	5.9 V	U1N	229 V	CP-	-11.6 V	U2N	13 V	D	21.3 %	U3N	12 V	Freq	1000.0 Hz	req	1000.0 Hz	evlse	12.8 A	evlse	12.8 A	State	C2	toff	36 ms ✓			State	E
Diagnostic Test (EVSE)		Diagnostic Test (EVSE)																																	
CP+	5.9 V	U1N	229 V																																
CP-	-11.6 V	U2N	13 V																																
D	21.3 %	U3N	12 V																																
Freq	1000.0 Hz	req	1000.0 Hz																																
evlse	12.8 A	evlse	12.8 A																																
State	C2	toff	36 ms ✓																																
		State	E																																
Bluetooth connection With MI3152/55 	<table border="1"> <tbody> <tr> <td>CP+</td><td>5.8</td><td>v</td><td>U1N</td><td>226</td><td>v</td></tr> <tr> <td>CP-</td><td>-11.8</td><td>v</td><td>U2N</td><td>13</td><td>v</td></tr> <tr> <td>D</td><td>21.1</td><td>%</td><td>U3N</td><td>12</td><td>v</td></tr> </tbody> </table>	CP+	5.8	v	U1N	226	v	CP-	-11.8	v	U2N	13	v	D	21.1	%	U3N	12	v		Remote Operation with Android App														
CP+	5.8	v	U1N	226	v																														
CP-	-11.8	v	U2N	13	v																														
D	21.1	%	U3N	12	v																														

Diagnostic Tests

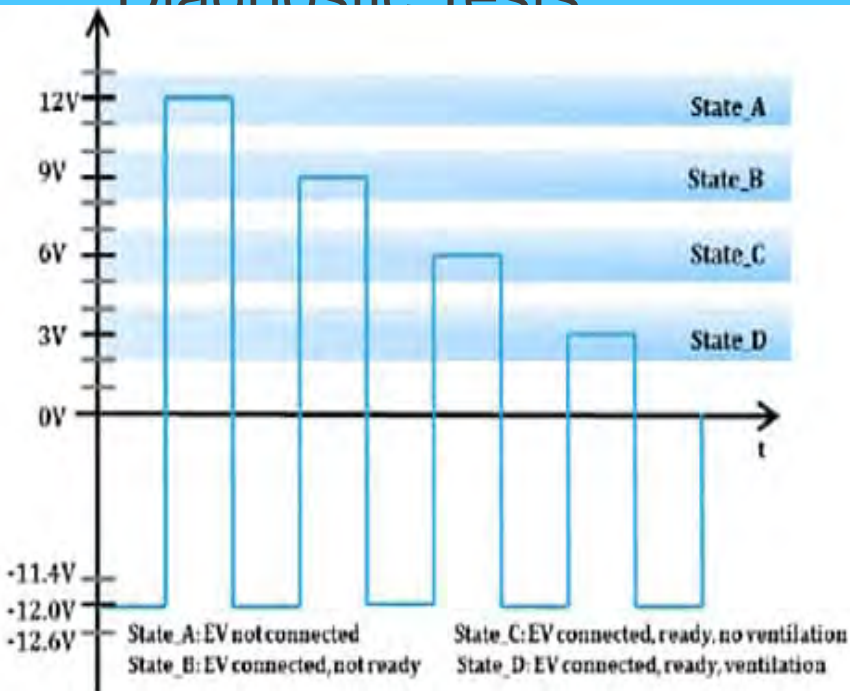

State	Peak Volts	EV Connected	STATUS	Charging Possible	Notes
A	12	No	Standby	No	EVSE not connected
B	9	Yes	Vehicle Connected	No	
C	6	Yes	Charging Allowed	Yes	
D	3	Yes	Ventilation	Yes/No	
E	0	Yes	EVSE shutdown	NO	EVSE problem or CP short

Diagnostic Test (EVSE) 09:10

CP+ 5.9 V **U1N** 229 V
CP- -11.6 V **U2N** 13 V
D 21.3 % **U3N** 12 V
Freq 1000.0 Hz
levse 12.8 A

State C2

Test EV simulator
Simulator CP C
Simulator PP 32 A
Duration Off
Control Remote (Bluetooth)

Diagnostic Test (EVSE) 22:15

CP+ 6.0 V **U1N** 0 V
CP- -11.8 V **U2N** 0 V
D 21.3 % **U3N** 0 V
Freq 1000.0 Hz
levse 12.8 A **toff** 36 ms

State E

Test Errors
Toff C -> E2

NEW EV TESTER

PRELIMINARY

Electric Vehicle tester
MI 3132 EV Tester

NEW

Electrical Installation Safety



MI 3132 EV Tester is a portable battery powered test instrument with excellent IP protection and designed especially for electric vehicle testing. The instrument support the latest standard UN ECE R100 Annex 4A, 4B and Annex 5, intended for measurement of insulation resistance for electric vehicle. The instrument is ergonomic in design with intuitive user interface, encompassing a memory organizer and fully programmable AUTO SEQUENCES, managed through a large colour touch screen display. Besides those, the instrument supports a wide range of tests and measuring functions, including 2 A Micro Ohm measurement, on line voltage monitoring, phase sequence testing, as well as functional and visual inspections.

MEASURING FUNCTIONS

- Insulation measurements according to **UN ECE R100** and **ISO 6469-3** with own REESS as DC voltage source;
- Discharge time measurement;
- **Insulation resistance** with DC voltage from 50 V to **1500 V**;
- DC voltage;
- TRMS voltage and frequency measurements;
- **Four wire Micro Ohm** measurements with **2 A DC** test current;
- Low Ohm measurements with 7 mA and 200 mA DC test current;
- Visual safety and functional inspections.

KEY FEATURES

- Insulation resistance measuring according to UN ECE **R100** measuring using internal DC source;
- Performing accurate four wire measurements with quality **Kelvin clamps** and up to **2 A** measuring current;
- Settable duration and current direction (unidirectional or bidirectional);

- Insulation range: wide range of insulation test voltages from 50 V to **1500 V**, resistance measuring range up to 3 GΩ;
- Overvoltage category 1000 V CAT II, 600 V CAT III;
- 4.3" colour LCD display with touch screen;
- **Programmable AUTO SEQUENCES**;
- High degree of protection;
- DC resistance measurements;
- Support for single or automated measurements;
- Built-in charger and rechargeable **Li-Ion batteries** as standard accessory;
- **BT communication** with PC, Android tablets and smart phones via built-in BT module;
- **PC SW Metrel ES Manager** for measurement pre and post processing: preparation of the test structure, result download, tree-view, table view and graphical view, storing and printing.

APPLICATION

- Electric vehicle service and maintenance;
- In services, workshops and electric vehicle production plants;

- Electric vehicle after crash safety check;
- Electric car cables and components test.

STANDARDS

Functionality

- UN ECE R100
- ISO 6469-3

Electromagnetic compatibility

- EN 61326

Safety

- EN 61010 - 1
- EN 61010 - 2 - 030 c
- EN 61010 - 2 - 032
- EN 61010 - 031

EVSE testing examples

